

AWM 11 – UNIT 6 – SCALE REPRESENTATIONS

Assignment	Title	Notes to Self	Complete
1	<i>Review – Proportions</i>		
2	<i>Scale Drawings and Models</i>		
3	<i>Different Views of Objects</i>		
4	<i>Component Part Diagrams</i>		
	<i>Quiz 1</i>		
5	<i>Exploded Diagrams</i>		
6	<i>Isometric Drawings</i>		
7	<i>Perspective Drawings</i>		
	<i>Quiz 2</i>		
Practice Test	Practice Test How are you doing?	Ask teacher.	
Self-Assessment	Self-Assessment	On the next page, complete the self-assessment.	
Unit Test	Unit Test Show me your stuff!		

Self Assessment



On the following chart, indicate how confident you feel about each statement.

1 – I need more help

2 – I need more practice

3 – I could teach it !

Discuss this with your teacher *before* you write the test!

Statement	  
After completing this chapter;	
<ul style="list-style-type: none"> I can solve proportions 	
<ul style="list-style-type: none"> I can write scale statements and determine scale factor for scale drawings 	
<ul style="list-style-type: none"> I can draw a scale drawing or model to determine the dimensions of a 3-D object 	
<ul style="list-style-type: none"> I can draw scaled views and the component parts of a 3-D object 	
<ul style="list-style-type: none"> I can draw an exploded diagram of a 3-D object and explain how the pieces fit together 	
<ul style="list-style-type: none"> I can draw a 3-D object using isometric dot paper 	
<ul style="list-style-type: none"> I can draw a one point perspective drawing of a 3-D object 	

Vocabulary: Unit 6

component parts diagram

elevation

exploded diagram

horizon line

isometric drawing

perspective drawing

proportion

rate

ratio

scale drawing

scale factor

scale statement

vanishing point

view

REVIEW – PROPORTIONS

In a previous unit, you learned about ratios and proportions. In this unit you will use proportional reasoning to calculate the size in different situations. So it is important to review these concepts.

A **ratio** is a comparison between two numbers in the same units – that last part is extremely important in this unit. An example of a ratio is the number of hours I worked this week compared to the number of hours you worked this week. It could be written 18:15.

A **rate** is a comparison between two numbers with different units. An example is comparing the distance I rode on my bike compared to the time it took me to ride it, and could be written as 15 km / h (15 kilometres per hour).

An equation showing equivalent ratios or rates is called a **proportion**. To solve proportions, use the process Cross Multiply and Divide. Refer to that handout if you need to review the concept.

ASSIGNMENT 1 – SOLVING PROPORTIONS

Find the missing term by using cross multiply and divide. If necessary, round answers to one decimal place. SHOW YOUR WORK.

1. $\frac{x}{13} = \frac{7}{91}$

2. $\frac{90}{198} = \frac{5}{x}$

3. $\frac{12}{49} = \frac{x}{73}$

4. $\frac{12}{x} = \frac{5}{6}$

5. $\frac{x}{85} = \frac{76}{39}$

6. $\frac{34}{289} = \frac{2}{x}$

7) The ratio of Peter's age to Dorothy's age is 2:7. If Peter is 10 years old, how old is Dorothy? Show your work.

SKIP

SKIP

SCALE DRAWINGS AND MODELS

A **scale drawing** represents objects that are either too large or too small to be drawn to their actual size. In a scale drawing, all parts are in the same proportion of their true size. Examples of scale drawings are blueprints, maps, drawings from microscope views, and floor plans.

A **scale statement** is a ratio of the length of the drawing or model to the length of the actual object. The scale statement can be represented in these three ways:

in words: "three centimetres represents fifty centimetres."

using ratio notation 3:50 or as a fraction $\frac{3}{50}$

A model airplane kit is marked on the box with a scale statement of 3:50; this means that 3 units of measurement on the model represents 50 units of the same measurement on the actual airplane.

A **scale factor** is a scale statement written as a fraction where one of the numbers is 1.

s.f = $\frac{1}{2}$ or s.f. = $\frac{10}{1}$ You will use scale factors in proportion calculations.

Example 1: Write a scale statement for the objects below. Calculate the scale factors.

a)

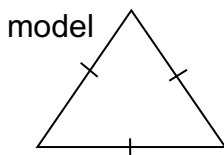

5 cm

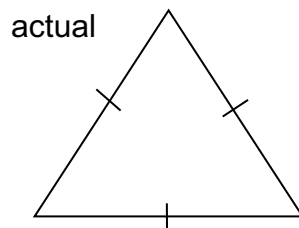

15 cm

scale statement = model : actual

scale statement = 5 : 15

This is a reduction because the model is smaller than the actual.

scale factor = $\frac{\text{model}}{\text{actual}}$

$$\text{scale factor} = \frac{m}{a} = \frac{5}{15} = \frac{1}{3}$$

Scale factors are always reduced to lowest terms.
A reduction will have a scale factor less than one.

b)

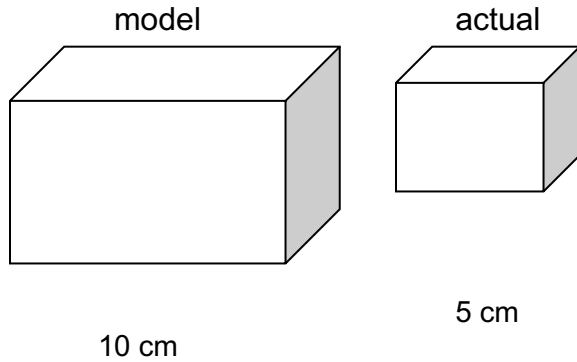

$$\text{scale statement} = \text{model} : \text{actual} \\ = 10 : 5$$

This is an enlargement because the model is larger than the actual.

$$\text{scale factor} = \frac{\text{model}}{\text{actual}} \quad \text{s.f.} = \frac{10}{5} \text{ or } \frac{2}{1} \text{ or } 2$$

An enlargement will have a scale factor greater than one.

Note that a model with a scale factor of 1 would be the exact size of the actual.

- c) A dining room table is 1.25 m long but on my blueprint it is 5 cm long. What is the scale factor used to make my blueprint drawing?

The dimensions MUST be in the same units in order to compare in a ratio.

Convert 1.25 m to cm by multiplying by 100.

$$1.25 \text{ m} \times 100 = 125 \text{ cm}$$

$$\text{scale statement} = \text{model} : \text{actual} \\ = 5 : 125$$

$$\text{scale factor} = \frac{\text{model}}{\text{actual}} \quad \text{s.f.} = \frac{m}{a} = \frac{5}{125} = \frac{1}{25} \quad \text{The scale factor is } \frac{1}{25} .$$

This is a reduction because the model is smaller than the original table (and the scale factor is less than 1).

Scale statements and scale factors cannot have decimals or fractions as part of the ratio or the numerator or denominator in the final answer. If this occurs, you must multiply or divide to eliminate them.

Example 2: An architect drew a plan for a new house where $\frac{1}{4}$ inch represents 1 foot.

a) Write this as a scale statement

b) Write this as a scale factor in the form $\frac{1}{x}$

c) If a room on the plan has a length of $5\frac{1}{4}$ inches, how long (in feet) is the room?

Solution: a) To write the scale statement, both parts need to be in the same units, and cannot include fractions.

scale statement = model : actual or plan : actual house

$$= \frac{1}{4} \text{ in} : 1 \text{ ft} \text{ (rewrite with same units)}$$

$$= \frac{1}{4} : 12 \text{ (multiply both sides by 4 to eliminate the fraction)}$$

$$= 1 : 48$$

b) Written as a scale factor in the form $\frac{1}{x}$, the scale factor is $\frac{1}{48}$.

c) Change the length of the room to a decimal number. Then use a **proportion** including the scale factor and the known information to solve for the length of the room. Cross multiply and divide to get the answer.

$$5\frac{1}{4} = 5 + 1 \div 4 = 5.25 \text{ inches.}$$

words	scale factor	known information		or	$\frac{d}{a}$	$\frac{1}{48}$	=	$\frac{5.25in}{x}$
$\frac{\text{drawing}}{\text{actual}}$	$\frac{1}{48}$	=	$\frac{5.25}{x}$	or	$\frac{d}{a}$	$\frac{1}{48}$	=	$\frac{5.25in}{x}$

$$x = 48 \times 5.25 \div 1 = 252 \text{ in}$$

$$252in \times \frac{1ft}{12in} = 21ft$$

The actual length of the room 21ft.

ASSIGNMENT 2 – WORKING WITH SCALE DIAGRAMS

1) Write a scale statement and calculate the scale factor for the figure below.

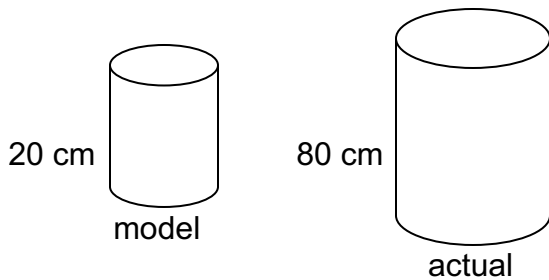

→ convert to cm ($\times 100$)

2) A volleyball court measures 8.5 m long. A drawing of the court shows that the length is 4.25 cm. Write a scale statement and calculate a scale factor for the court.

2

3) The distance between Calgary and Vancouver is approximately 675 km in a straight line. The distance on a map is 2.25 cm. Write a scale statement for this situation. What is the scale factor used to make this map?

→ $\times 100,000$
+0 get cm

2

4) You take a picture of a boy is standing beside a giant redwood tree. In the picture, the boy measures 2.3 cm and the tree measures 12.6 cm. If you know that the boy is really 1.15 m tall, how tall actually is the tree?

3

5) A baby killer whale that is 4.1 m long is shown on the internet with this picture.

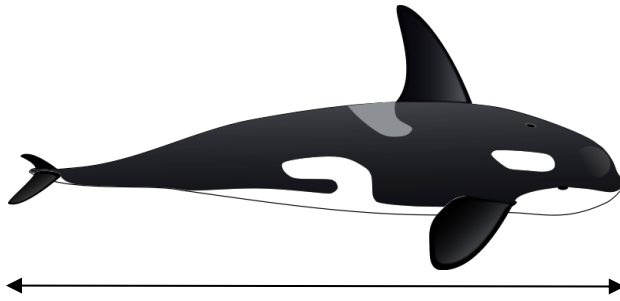

a) Measure the length of the killer whale (the line, in mm) and write a scale statement for the picture.

b) What is the scale factor of this diagram? Express your answer as a fraction.

c) If a boat is drawn at the same scale, and the drawing is 17.8 cm long, what is the actual length of the boat? Express your answer in m, rounded to the nearest metre.

d) How long would a dolphin be in the picture if it is actually 2.5 m long? Express your answer in cm, rounded to 1 decimal place.

6) The coastline of Vancouver Island is approximately 3440 km long. If a map of Vancouver Island is drawn with a scale of 3 cm : 120 km, how long would the coastline be on the map?



7) For 34 years, the CN Tower in Toronto was the tallest free-standing structure in the world. It measures approximately 455 metres tall with an antenna that extends another 95 meters. A souvenir model of the tower without the antenna is 9.1 cm tall.

a) What is the scale factor used to make the model?

4

b) How long would the antenna be on this model at this scale factor? Express your answer in cm, rounded to 1 decimal place.

8) A flag pole is 22.5 m tall. If the scale factor is 1:500, what is the height of the flag pole in a diagram? Express your answer in cm, rounded to 1 decimal place.

SKIP

9) A micro-photograph of a human hair shows the hair magnified 150 times. If the hair is 2 cm wide in the photograph, what is the actual width of the hair? Express your answer in mm, rounded to 2 decimal places.

4

10) The new Surrey Centre has several tall buildings. On a model of the area, one building was 16.6 cm tall and another was 15.0 cm tall. How tall are these two buildings if the scale factor used was 1 cm:10 m? Express your answer in m, rounded to the nearest metre.

SKIP

DIFFERENT VIEWS OF OBJECTS

When you are looking at a floor plan of a house or room, you are looking at a plan view, or bird's eye view. You can also create views that show the front or side or back of a building or other object. A **view** is a two-dimensional, or flat, representation showing one face of an object. Views are also known as **elevations**. Drawings of different views can help imagine what the real object looks like.

Consider the following pictures. The first view is the side of a car, while the middle two views show the front on the left and the rear on the right. Finally, the last diagram is the top or bird's eye view of the car.

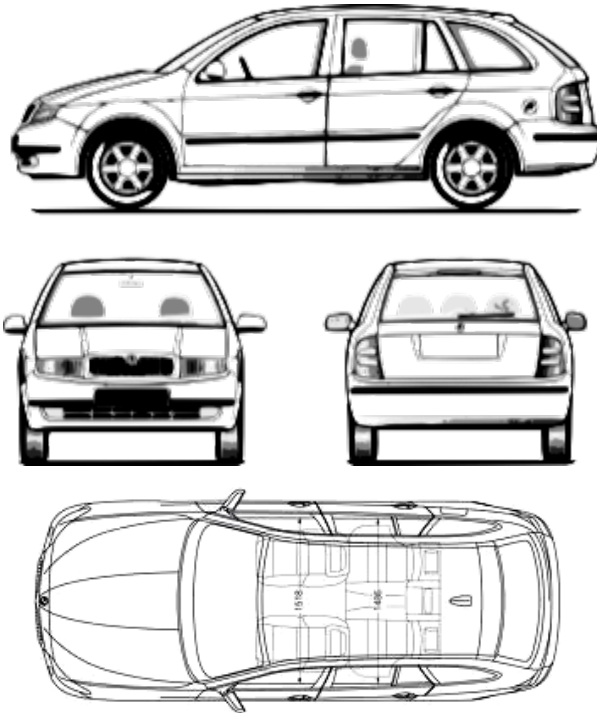

Notice that there are things that can be seen in one view that are not visible in another view. For example, you cannot see the tires in the top view, but you can see the whole roof. All these views are necessary to understand what the whole object really looks like.

In this section, you will be drawing the different views of simple objects, but nothing as complicated as a car!

Example: Given the birdhouse below, draw the view of each face and label the dimensions.

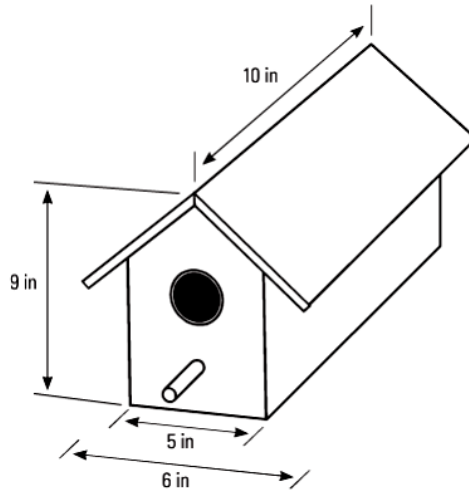

Solution: It is not necessary to draw the sides to scale, nor must they be exactly the right length. This is a view that is a representation of the real object.

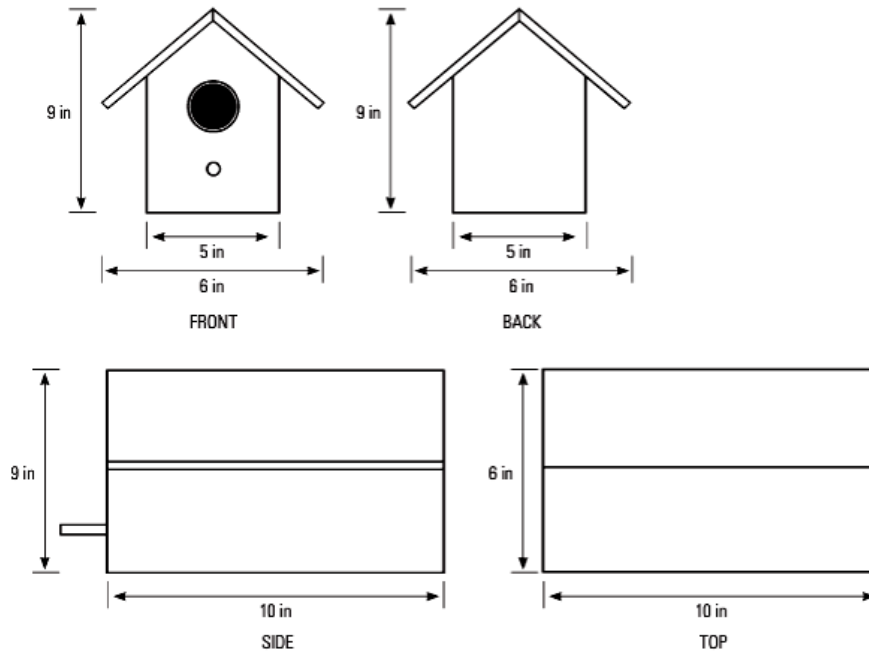

ASSIGNMENT 3 – DRAWING DIFFERENT VIEWS OF OBJECTS

1) On the grid paper, draw the front and side views of the sets of blocks. If you have difficulty, ask your teacher for some blocks to build a model to see in 3-D.

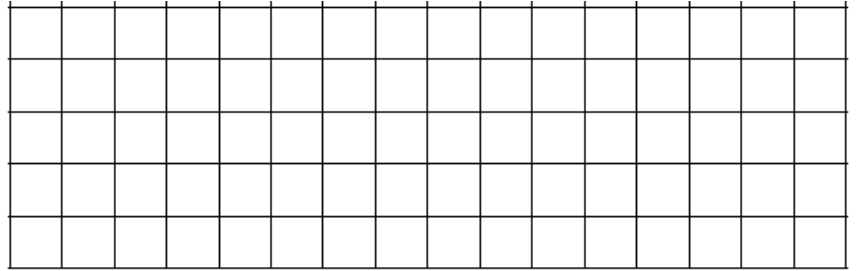
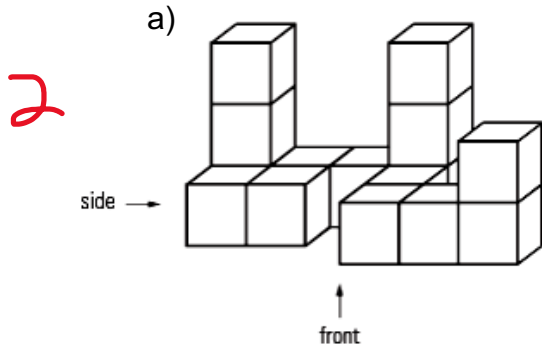

Front

Side

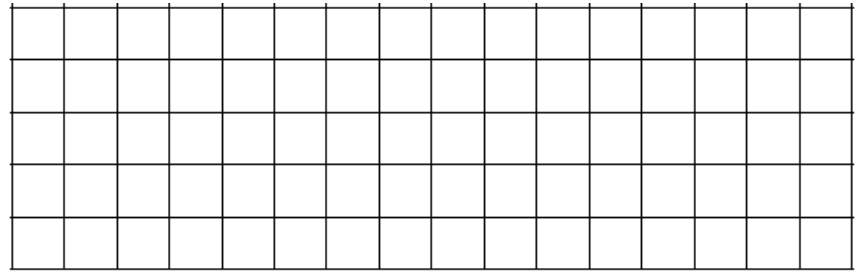
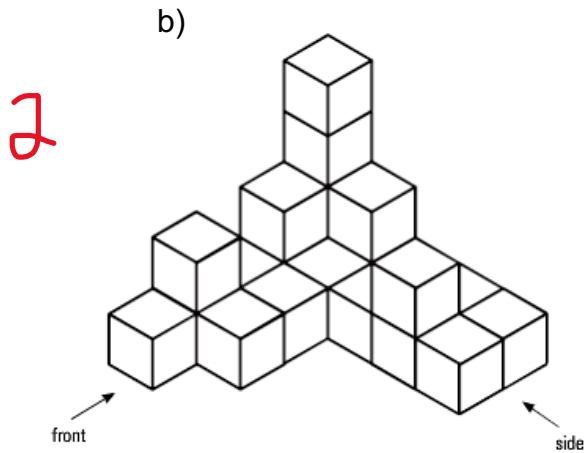

Front

Side

2) Sketch the front and side views of this object. Label the dimensions.

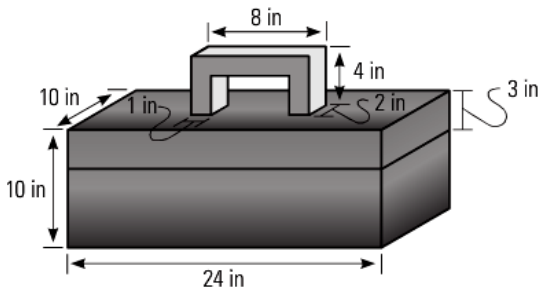

COMPONENT PARTS DIAGRAMS

While different views show what the sides of an object look like, a **component parts diagram** shows all the parts needed to assemble an object. Furniture from IKEA comes with a sheet of assembly instructions with a composite parts diagram. This is a scale diagram showing each part of the object.

Example: A toy box is in the shape of a rectangular prism. The box is 150 cm long, 90 cm deep, and 90 cm high as shown below. There is no lid.

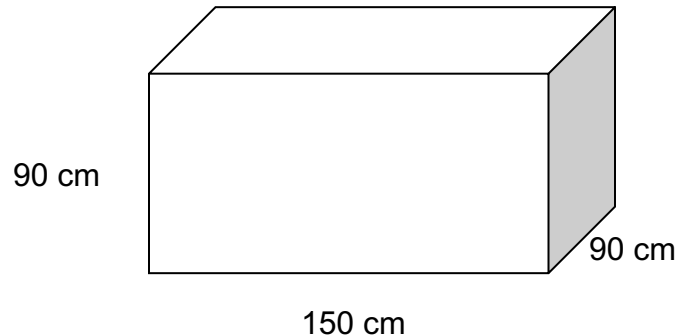

Draw the component parts using a scale of 1:30.

Solution: Using the scale factor given, determine the diagram size of the different rectangular pieces needed. Then draw them appropriately.

The front, back and bottom of the toy box are all the same size. This is Face 1.

$$\text{Face 1: length } \frac{\text{drawing}}{\text{actual}} \quad \frac{1}{30} = \frac{x}{150} \quad x = 1 \times 150 \div 30 = 5 \text{ cm}$$

$$\text{Face 1: width } \frac{\text{drawing}}{\text{actual}} \quad \frac{1}{30} = \frac{x}{90} \quad x = 1 \times 90 \div 30 = 3 \text{ cm}$$

$$\text{End length \& width } \frac{\text{drawing}}{\text{actual}} \quad \frac{1}{30} = \frac{x}{90} \quad x = 1 \times 90 \div 30 = 3 \text{ cm}$$

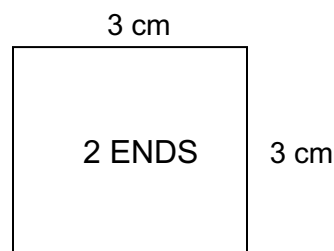
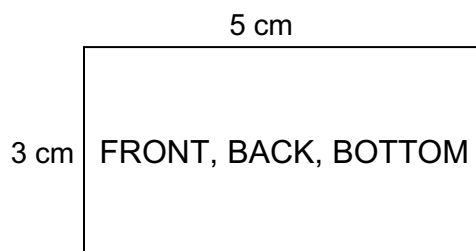

ASSIGNMENT 4 – DRAWING COMPONENT PARTS

1) Draw the **component** parts of the bookcase. Label the dimensions. Drawing does not need to be to scale.

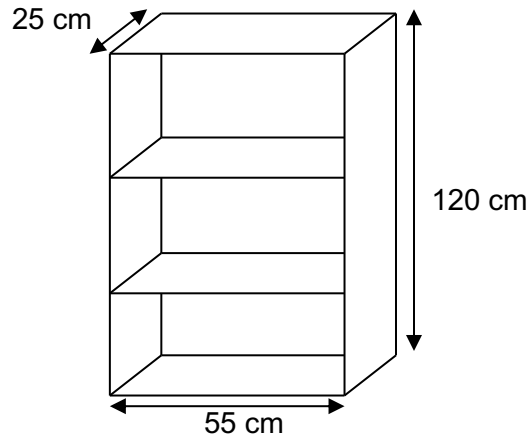

2) Draw the component parts of this table. Label the dimensions. Drawing does not need to be to scale.

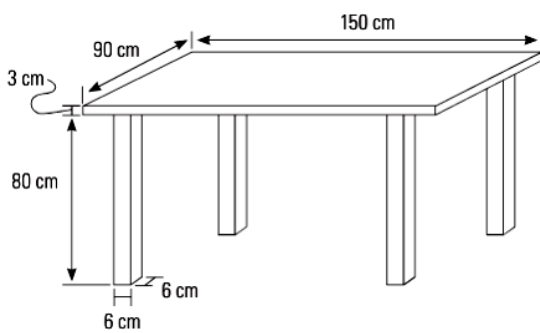

3) Draw the component parts of this feed bin for horses. There are 6 different parts. Label the parts with the dimensions given. Ignore the thickness of the wood.

3

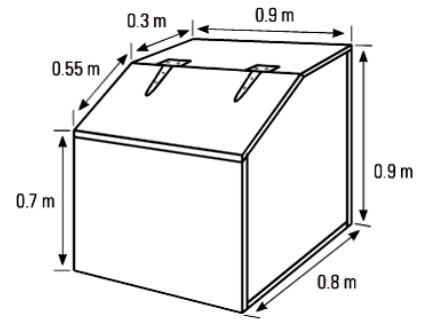

4) Draw the component parts of this cat scratching platform. There are 4 different parts. Label the parts with the dimensions given. Ignore the thickness of the wood.

4

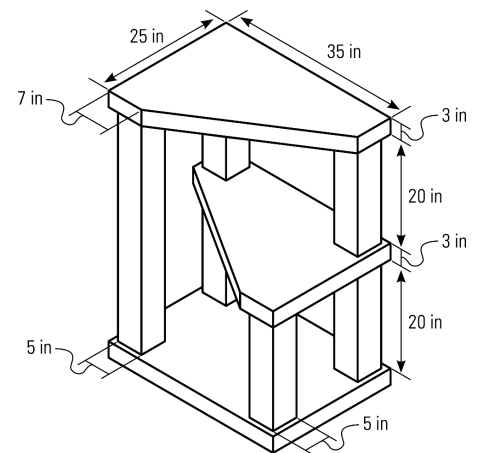

ASK YOUR TEACHER FOR QUIZ 1

EXPLODED DIAGRAMS

An **exploded diagram** shows the relationship between the component parts of an object. It is a 3-D representation of how the components connect or fit together. The components are shown separated but in their relative positions, and often dotted lines show where the pieces fit together. You might see such a diagram in the instructions for the furniture that you assemble from IKEA or other stores. Or you might see this kind of diagram with a model or toy that needs assembling. Even automotive parts and food can have exploded diagrams associated with them.

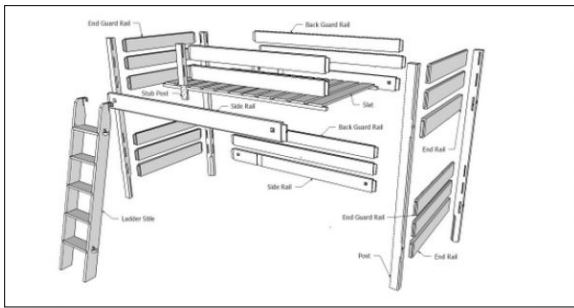

Bunk Bed

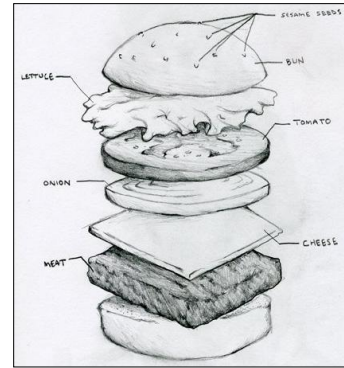

Cheeseburger

Example: Sketch an exploded diagram of the bookcase below.

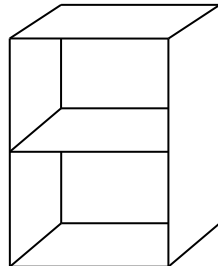

Solution: The parts are the back, top, bottom, sides, and shelf. Start by drawing the back and then the parts separately so that they fit together. Draw the dashed lines to show how the parts connect.

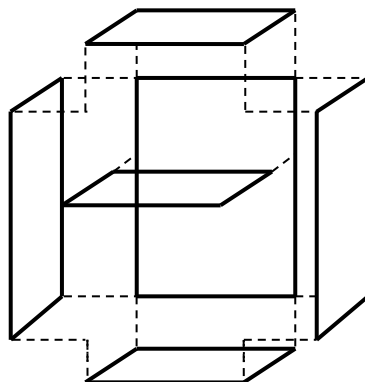

ASSIGNMENT 5 – DRAWING EXPLODED DIAGRAMS

1) Sketch an exploded view of this box.

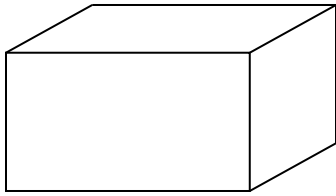

2

2) Sketch an exploded view of this planter.

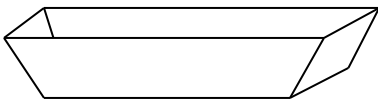

2

3) From this exploded view, sketch what the bookcase would look like.

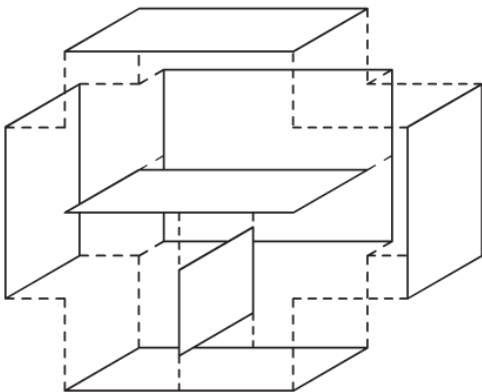

ISOMETRIC DRAWINGS

An **isometric drawing** is a way of representing a three-dimensional object on a two-dimensional plane. Isometric drawings are done on special dot paper where lines that are drawn to represent width and height are shown at an angle of 30° from the horizontal. **Vertical lines are always vertical lines.** Isometric drawings are also drawn to scale and lines that are parallel in real life are parallel in the drawing.

This is a section of isometric dot paper. When drawing objects on this kind of paper, it is helpful to orient drawings as shown.

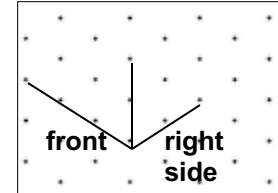

Example: Use isometric dot paper to draw a cube with sides that are each 3 units long.

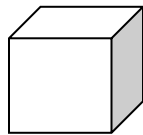

Solution: To draw the cube shown above, draw the front face so that the height is vertical and the width is diagonal. Follow these steps.

- Start with the bottom right corner in the middle of the dot paper.
- Draw the vertical line segment going up 3 squares that represents the edge on the right.
- Draw lines up to the left and up to the right from the bottom point.
- Draw vertical lines up from these two endpoints.
- Join the tops of the three vertical lines to form parallel lines to the base lines.
- From the top of the left vertical line, go up to the right for 3 squares.
- From the top right vertical line, go up to the left for 3 squares to meet the other line.
- Your cube should now be complete.

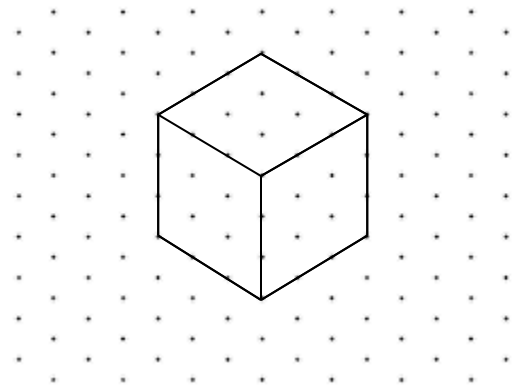

Notice: vertical lines remain vertical on isometric paper and lines representing **depth and width are drawn on the diagonal**. Parallel sides remain parallel.

Also remember that the scale of drawing always remains constant.

ASSIGNMENT 6 – CREATING ISOMETRIC DRAWINGS

1) Use isometric dot paper to draw a cube with sides that are each 4 units long.

2

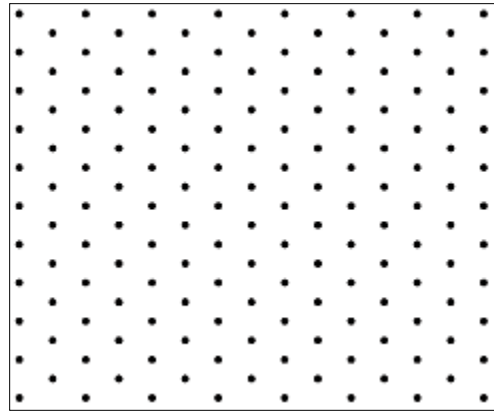
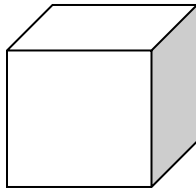

2) Use the isometric dot paper to draw the blocks shown below.

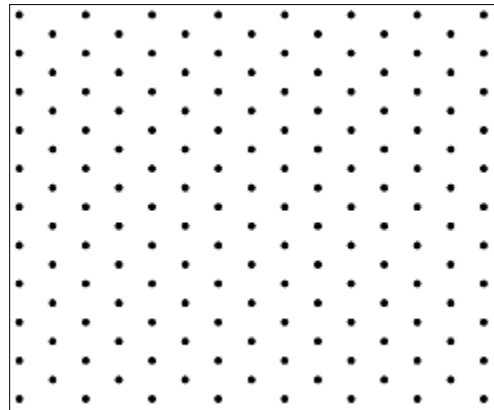
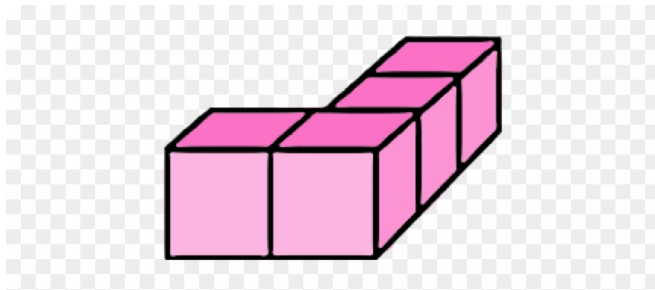

3) Use the isometric dot paper to draw the bookcase shown below. Use the corner indicated by the arrow as your starting point.

3

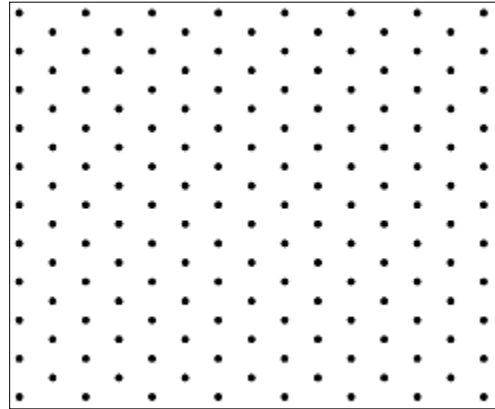
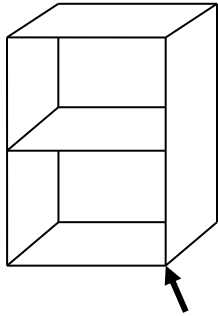

4) The following isometric drawing is a room, without the ceiling. The front wall is 18 feet long. Find the lengths of the walls labelled x , y , and z , and the height of the room, h . Remember, isometric drawings are always drawn to scale. Show your calculations.

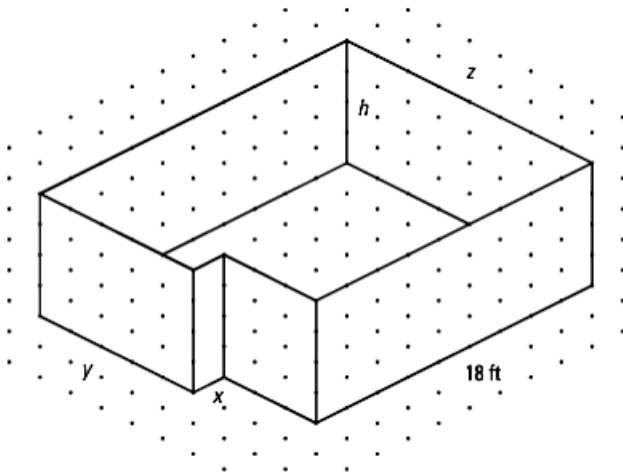

5) Draw an isometric representation of the partial objects below. Extend the drawing to the length as indicated. Use the scale shown in the top left corner.

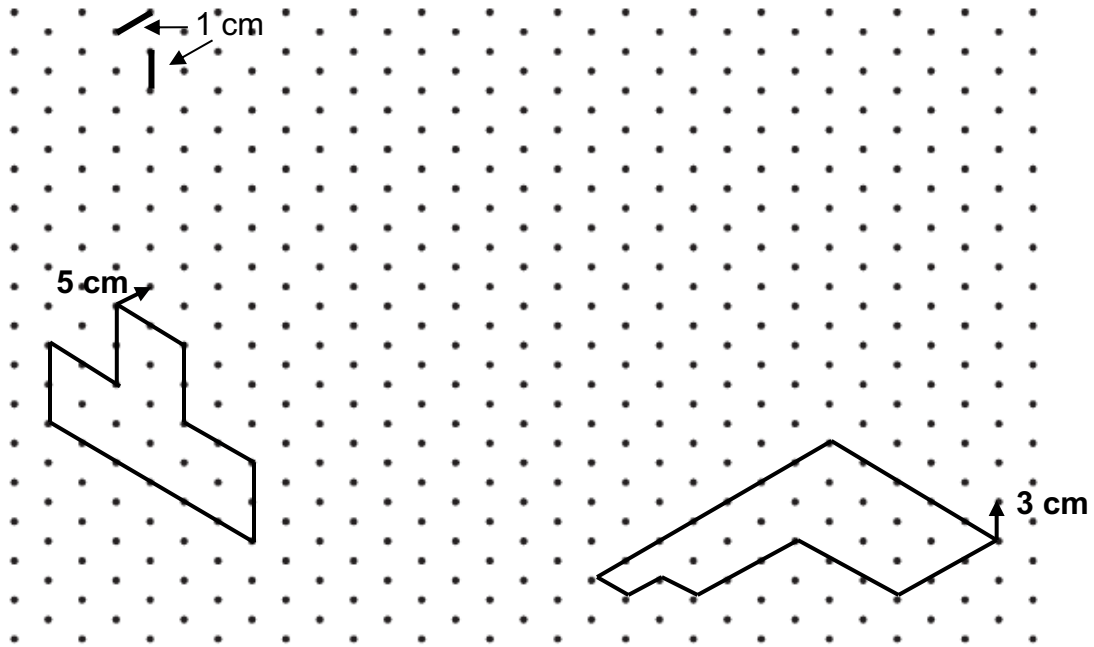

SLIP

6) Draw the shape below as an isometric drawing, at a scale of 1:10. Use the edge indicated by the arrow as your starting point. Remember vertical lines stay vertical!

4

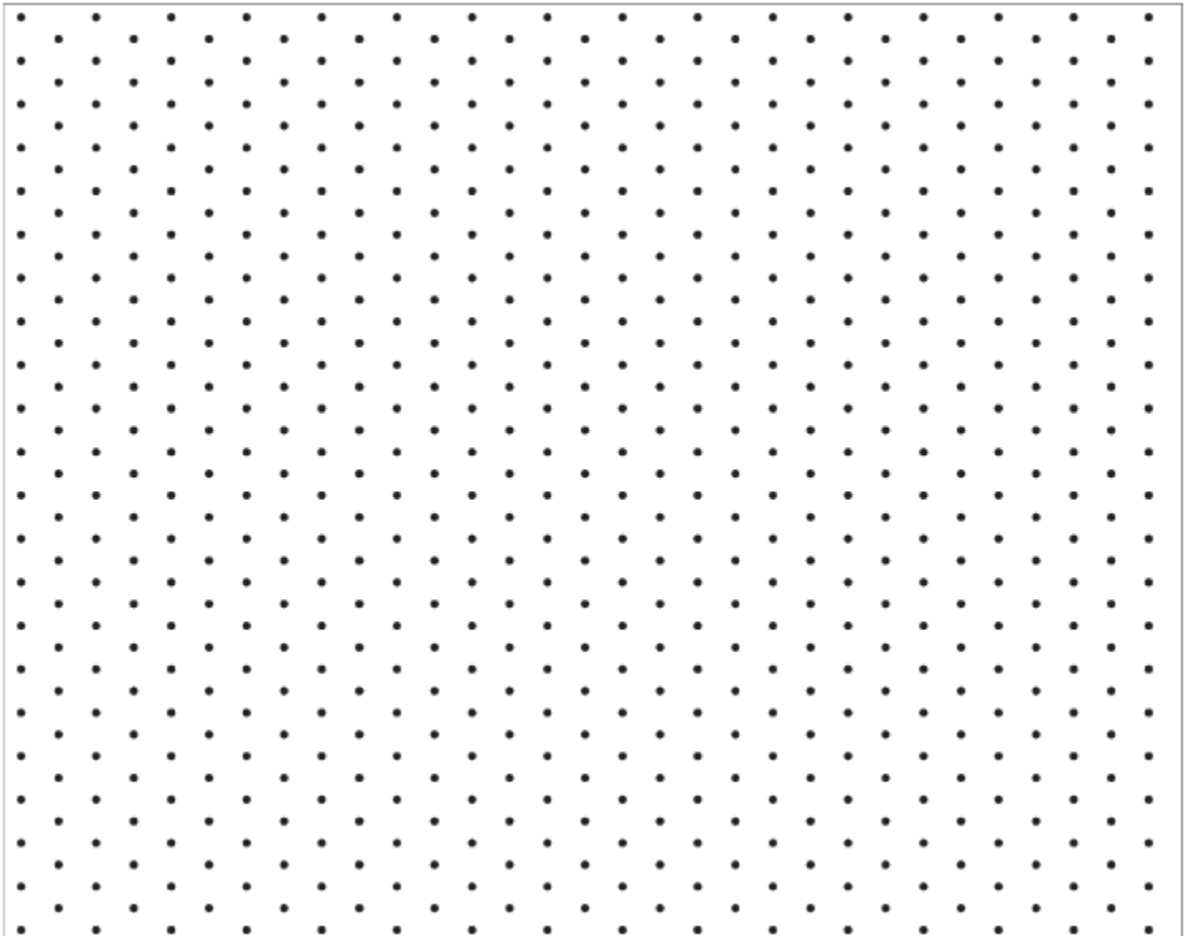
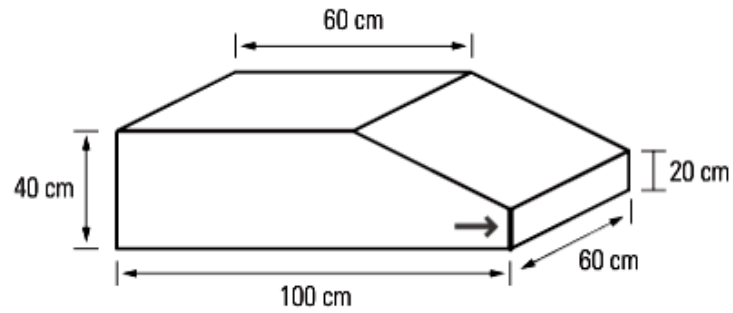

PERSPECTIVE DRAWINGS

While isometric drawings show drawings of 3-D objects in a two-dimensional plane at 30° angles, **perspective drawings** are drawings that try to represent objects as we actually see them. Perspective drawings use the idea that parallel lines appear to intersect at a point on the **horizon line** – a horizontal line that is not always visible and is at eye level of the viewer. The point on the horizon line where the parallel lines appear to converge is called the **vanishing point**. In perspective drawings, the further objects are away from the viewer, the smaller they appear.

Example: Use a perspective drawing to draw a rectangular prism.

Solution:

Step 1: Draw a horizon line and a vanishing point H on the line. Draw a rectangle below and on one side of the vanishing point.

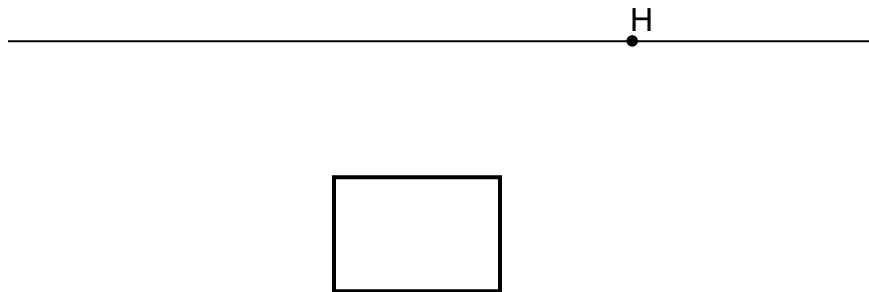

Step 2: Draw lines from the corners of the rectangle to the vanishing point.

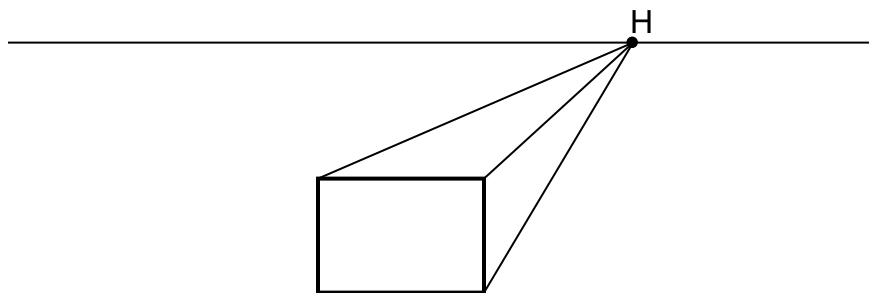

Continued on the next page.

Step 3: Mark a point, called X, anywhere on the line joining the top left corner to the vanishing point and draw a line **parallel** to the top of the rectangle. Label the end on the line joining the top right corner to the vanishing point Y.

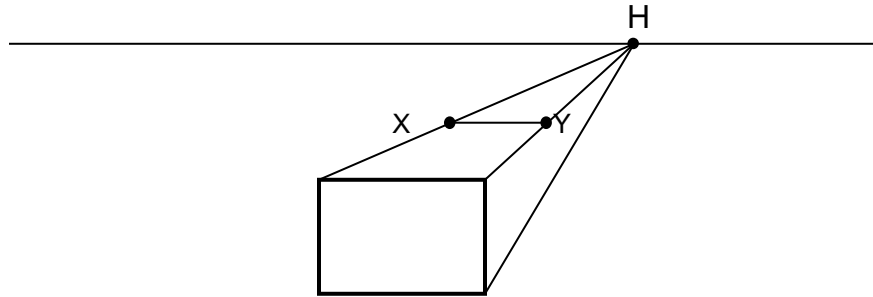

Step 4: Draw a **vertical** line from point Y to the line joining the bottom right corner to the vanishing point. Label it Z.

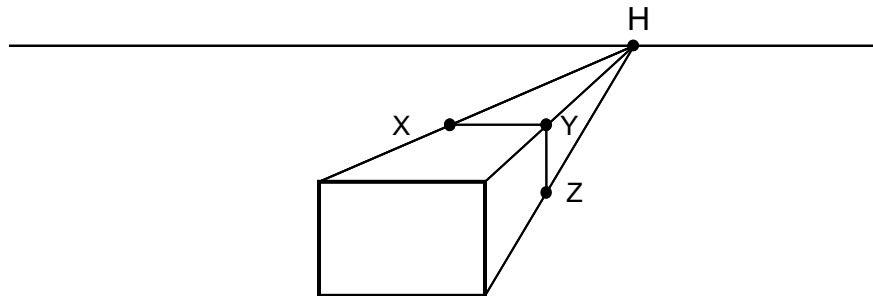

Step 5: Now that the rectangular prism is completed, **erase** the horizon line and the lines joining the prism to the vanishing point.

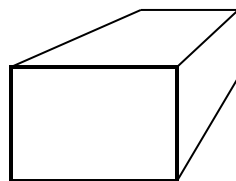

ASSIGNMENT 7 – CREATING PERSPECTIVE DRAWINGS

1) Draw two perspective drawings of the rectangular prism below, using the two vanishing points given. What differences do you notice?



2) Draw a perspective drawing of the object shown below.

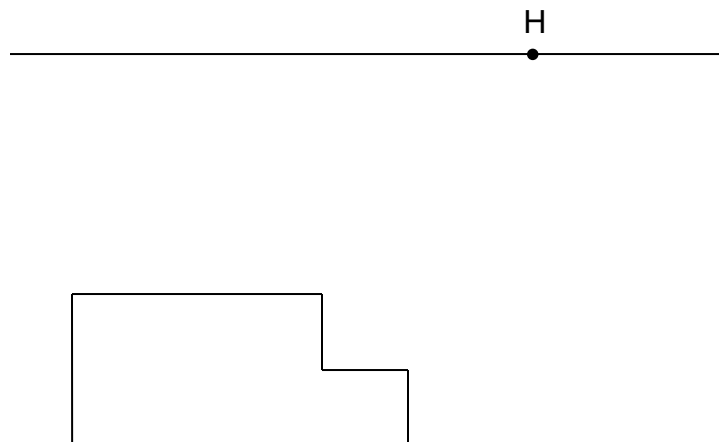

ASK YOUR TEACHER FOR QUIZ 2

AWM UNIT 6 – SCALE REPRESENTATIONS – ANSWERS

ASSIGNMENT 1 – SOLVING PROPORTIONS

1) 1 2) 11 3) 17.9 4) 14.4 5) 165.6 6) 17 7) Dorothy is 35 years old.

ASSIGNMENT 2 – WORKING WITH SCALE DIAGRAM

1) scale statement = 20:80, scale factor = $\frac{1}{4}$ 2) SS=4.25:850 SF=1/200 3) SS=2.25:67500000
SF= 1/30 000 000 4) 6.3 m 5a) 82:4100 b) 1/50 c) 9 m d) 5.0 cm
6) 86 cm 7a) 1/5000 b) 1.9cm 8) 4.5 cm 9) 0.13 mm 10) 166m & 150 m